

VENTS Simple Series



Axial fans for exhaust ventilation with air capacity up to 280 m³/h

Application

- Continuous or periodic exhaust ventilation of bathroom, showers, kitchens and other utility spaces.
- Ventilation shaft mounting or duct connection.
- Low to medium air flow motion for short distances at low air resistance.
- Compatible with Ø 100, 120, 125 and 150 mm air ducts.

Design

- Modern design and aesthetic look.
- The casing and the impeller are made of high-quality durable ABS plastic, UV resistant.
- The intellectual impeller design makes the fan efficiency high and the service life long.
- Insect screen.
- Protection rating IP34.

Motor

- Reliable and low-watt electric motor.
- Designed for continuous operation and requires no maintenance.
- Equipped with overheating protection.

Modifications and Options



Simple K – fan is equipped with a backdraft damper for back flow preventing.



Simple L – the motor is equipped with ball bearings for long service life (appr. 40 thousand hours) and fan mounting at any angle. The bearings are maintenance-free and contain enough grease for the entire operating period.



Simple turbo – high-powered motor.



Simple T – equipped with a regulated timer with the operating time from 2 to 30 minutes.



Simple TH – equipped with a timer with the operating time from 2 to 30 minutes and a humidity sensor with the threshold value from 60 to 90 %.



Simple V – equipped with a pull cord switch.



Simple VT – equipped with a pull cord switch and a regulated timer with the operating time adjustable from 2 to 30 minutes.



Simple VTH – equipped with a pull cord switch, regulated timer with the operating time adjustable from 2 to 30 minutes and a humidity sensor with the operating threshold range from 60 to 90 %.

Control

Manual:

- The fan is controlled by a room light switch. It is not included in the delivery set.
- The fan is controlled by the built-in **V** pull cord switch. Not applied in case of ceiling mounting.
- Speed control is possible through a thyristor speed controller (see Electrical Accessories). Several fans may be connected to the same controller. Speed controllers can not be connected to the fans with the T, TH, TP, VT, VTH modifications.

Automatic:

- By the **BU-1-60** electronic control unit (see Electrical Accessories). The control unit is supplied separately.
- By the **T** timer (the built-in turn-off delay timer enables the fan operation within 2 to 30 minutes after the fan switching off).
- By the humidity sensor and the **TH** timer (if the humidity level in the room exceeds the sensor threshold adjustable value within 60-90 %, the fan switches automatically on and operates until the humidity level drops to the standard level, after that the fan continues operating within the time period according to the timer setting, then shuts down).

Mounting features

- The fan is mounted directly into the ventilation shaft.
- In case of remote location of the ventilation shaft flexible air ducts may be used. The air duct is connected to the fan exhaust flange through a clamp.
- Fixed to the wall by means of screws.
- Can be ceiling mounted in case the fan is ordered with ball bearings (Simple L modification).

Accessories



Aerodynamic characteristics

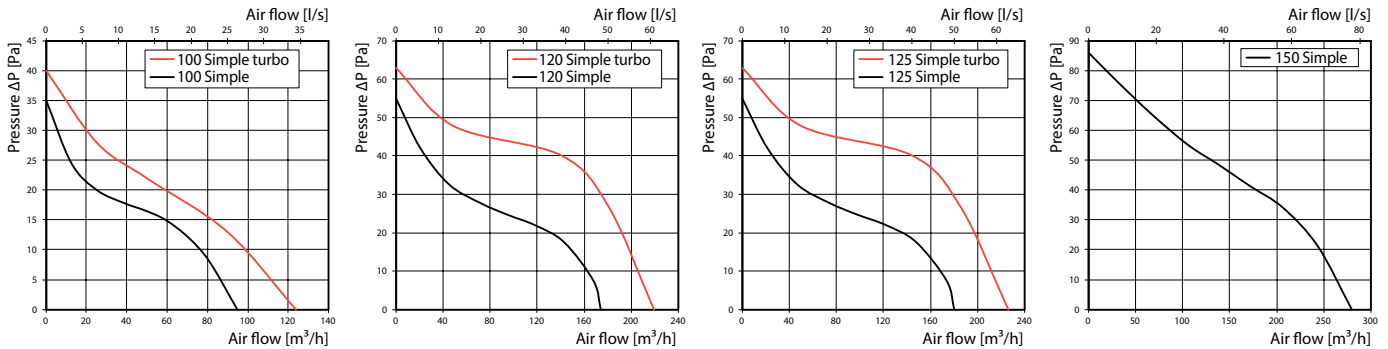

Technical data

Model	Frequency	Voltage	Power Consumption	Current	Maximum Air Flow		Specific Power	Sound Pressure Level [dBA]*	Weight	IP
	[Hz]	[V]	[W]	[A]	[m³/h]	[l/s]	[W/l/s]	[dBA]	[kg]	
VENTS 100 Simple	50	220-240	14	0.09	95	26	0.53	34	0.58	IP34
	60	220								
VENTS 100 Simple turbo	50	220-240	16	0.01	124	34	0.46	37	0.66	IP34
	60	220								
VENTS 120 Simple	50	220-240	16	0.09	174	48	0.33	35	0.74	IP34
	60	220								
VENTS 120 Simple turbo	50	220-240	24	0.1	219	61	0.39	37	0.81	IP34
	60	220								
VENTS 125 Simple	50	220-240	16	0.1	180	50	0.32	35	0.74	IP34
	60	220								
VENTS 125 Simple turbo	50	220-240	24	0.105	226	63	0.38	37	0.81	IP34
	60	220								
VENTS 150 Simple	50	220-240	25	0.17	280	78	0.32	34	0.92	IP34
	60	220								

*Sound pressure level measured in free space at a distance of 3 meters from the fan.

Mounting example



Overall dimensions

Model	Dimensions [mm]				
	Ø D	B	H	L	L1
VENTS 100 Simple	100	150	125	97	15
VENTS 120 Simple	120	175	140	94	15
VENTS 125 Simple	125	175	140	101	15
VENTS 150 Simple	150	205	165	117	15

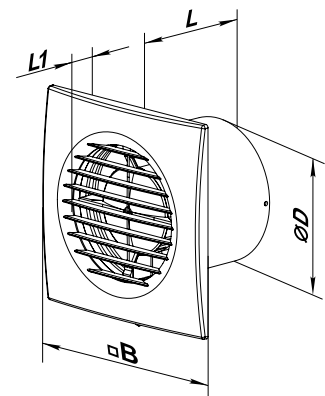

Certificates

The fans meet the applicable safety and electromagnetic compatibility standards.